



Note: Document originally drafted in the English language.  
注释：文件最初用英语起草。

**Product Description**

The Sapphire® housing is designed for Varex Imaging RAD series rotating anode inserts having 100mm (4 inch) diameter targets.

IEC Classification ..... Class 1

Weight, Approximate:  
Housing & Tube ..... 18.9 kg (41.6 lbs)

Mounting ..... Port plate or Trunnion  
Metric Housing - M6-1 screws

**产品说明**

Sapphire® 管套适用于具有 100 mm (4 in.) 直径靶盘的万睿视影像 RAD 系列旋转阳极管芯。

IEC 分级 ..... 1 类

近似重量：  
管与管套： ..... 18.9 kg (41.6 lbs)

安装 ..... 配流盘或管箍  
米制管套 - M6-1 螺钉

**Product Description**

Maximum Potential Difference .....	150 kV
Cathode to Ground .....	82.5 kV
Anode to Ground .....	82.5 kV
Maximum X-Ray Tube Assembly Heat Content .....	1,111 kJ (1,500 kHU)
Maximum Continuous Heat Dissipation (max. housing temperature 78°C)	
without air circulator .....	216 W (300 HU/sec)
with air circulator .....	432 W (600 HU/sec)
X-ray tube assembly cooling is provided by ambient air flow.	
X-Ray Tube Assembly (Insert and Housing)	
Permanent Filtration .....	0.7mm Al/75kV IEC 60522
Loading Factors for Leakage Radiation .....	150 kV, 4.0 mA
Humidity .....	10% to 90%
Temperature Limits for Storage and Transport .....	-20°C to +75°C
Atmospheric Pressure Range .....	70 kPa to 106 kPa
Thermal Switch .....	Normally Closed
	contact rating - 7A @ 120Vac or 30 Vdc Max.
Open .....	85°C ±3.9°C (185°F ±7°F)
Federal Standard High Voltage Cable .....	Complies to IEC 60526
X-Ray Tube Assembly (complies to) .....	IEC 60601-2-28

**产品说明**

最大电位差值 .....	150 kV
阴极到地 .....	82.5 kV
阳极到地 .....	82.5 kV
X 射线管组件最大热含量 .....	1,111 kJ (1,500 kHU)
最大连续散热 (最大管套温度 78°C)	
无风扇 .....	216 W (300 HU/sec)
配风扇 .....	432 W (600 HU/sec)
X射线管组件通过其周围空气流进行冷却。	
X 射线管组件 (管芯和管套) :	
固有滤过 .....	0.7mm Al/75kV IEC 60522
泄漏辐射测试条件: .....	150 kV, 4.0 mA
存储与运输温度限值: .....	-20°C 到 +75°C
湿度 .....	10% 到 90%
大气压范围 .....	70 kPa 到 106 kPa
热控开关 .....	正常闭合
	触点额定值 - 7A @ 120V 交流或 7A @ 30V 直流
	(最大)
打开 .....	85°C ±3.9°C (185°F ±7°F)
联邦标准高压电缆 .....	符合 IEC 60526
X 射线管组件 (符合) .....	IEC 60601-2-28

**Metric Port Housing**

米制端口管套

Dimensions are for Reference only  
维度是供仅供参考

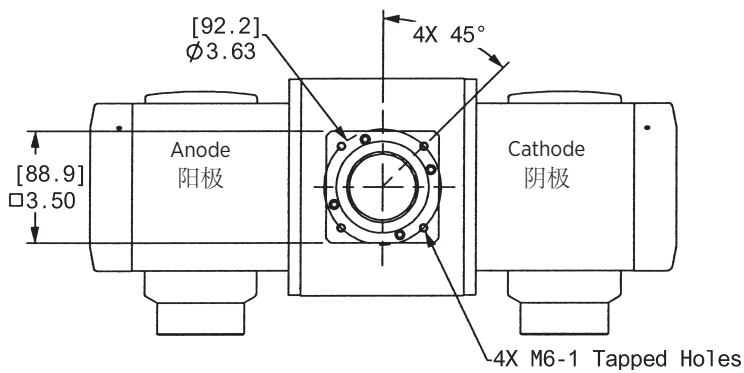
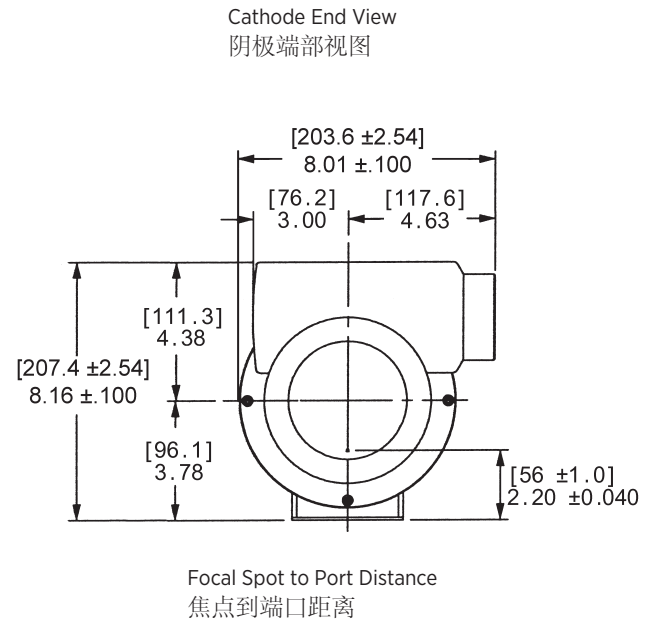
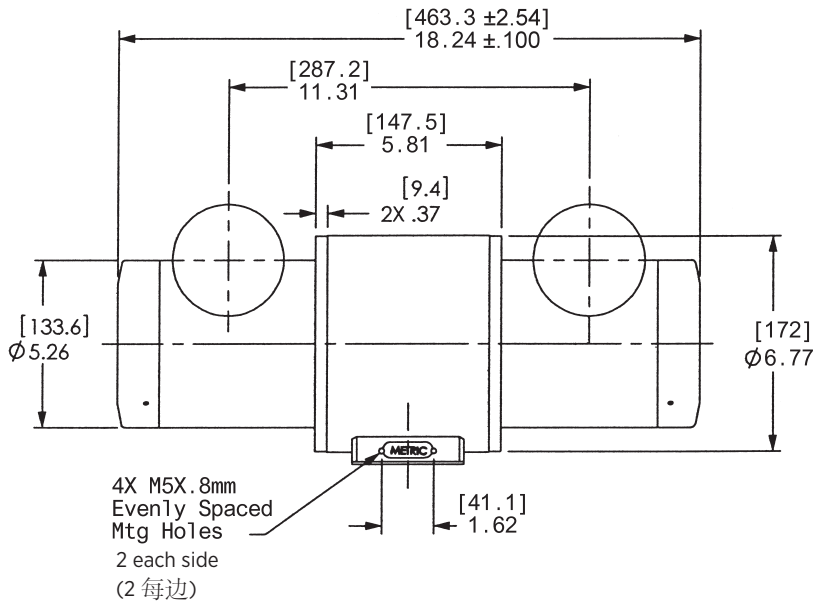

Housing Horn Angles

管套号形角

Cathode End View

阴极端部视图

0° Terminals  
0° 端子

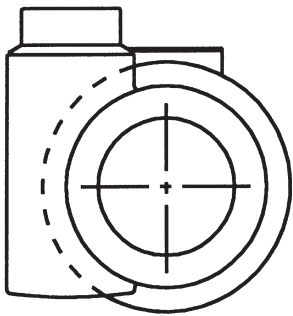

180° Terminals  
180° 端子

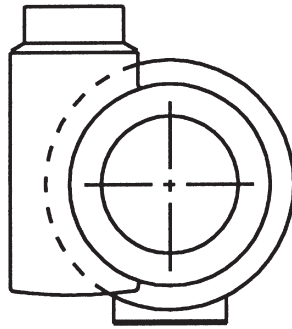

270° Terminals  
270° 端子

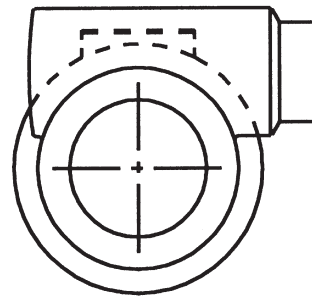

Central Ray and Reference Axis  
中心射线及参考轴

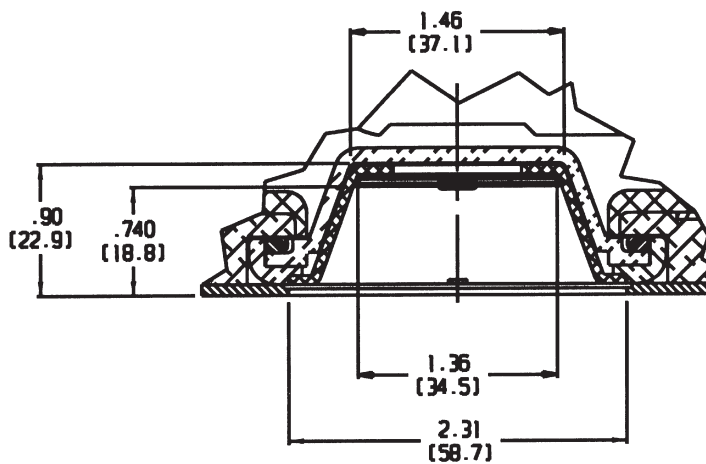

Cross Section of Port  
端口的横截面

Dimensions are for Reference only  
维度是供仅参考

Filter Assembly  
过滤组件

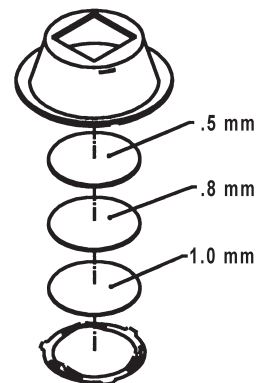

Optional  
Filter Kit - IK163  
P/N 7576  
可选  
过滤套件 - IK163  
P/N 7576

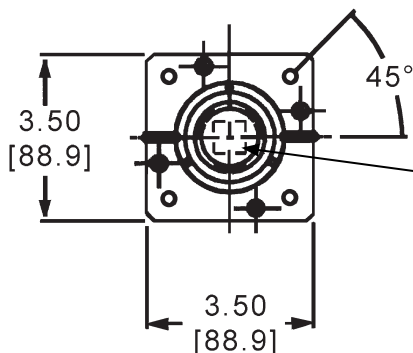

Note: Window aperture is .875" (22mm) square on 16° anode and .656" (16.7mm) square on 10° and 12° anodes.

注释: 16° 阳极的窗口孔径是边长为 0.875" (22 mm) 的正方形, 10° 和 12° 阳极的窗口孔径是边长为 0.656" (16.7 mm) 的正方形。

Stator Motor Ratings: 定子电机额定值:	Frequency (Hz) 频率 (赫兹)	Volts 伏特	White Lead Amperes (Typical) 白色导线电流 (典型)
*Run Voltage *工作电压 (运行)	<b>60 Hz</b>	50 - 60*	2.0
		120	4.2
		220	8.2
	<b>180 Hz</b>	100*	2.0
		220	4.0
		290	6.0
		320	7.0
		450	9.5
		550	11.5

"R" Stators	"R" 定子	标称	可接受
Black - White	黑色 - 白色	20 Ω	18 - 22
White - Red	白色 - 红色	50 Ω	45 - 55
Black - Red	黑色 - 红色	70 Ω	63 - 77
180 Hz Cap	180 Hz 电容	6 μF	
150 Hz Cap	150 Hz 电容	9 μF	
60 Hz Cap	60 Hz 电容	30 μF	
50 Hz Cap	50 Hz 电容	43 μF	

Stator Drive Frequency 定子驱动频率	RPM
50 Hz	2800 - 3000
60 Hz	3400 - 3600
150 Hz	8500 - 9000
180 Hz	9500 - 10,800

#### Stator Power:

Time to full speed of the anode is a function of the power rating of the "starter" and the weight / diameter of the anode. All Varex Imaging stator types are rated for regular speed and high speed starters. Time to full speed of 102 mm (4 inch) anode series tubes is between 1.3 and 2.0 seconds.

Immediately following high speed anode rotation, the rotor speed must be reduced to 4000 r/min or less within 10 seconds using a suitable dynamic braking device.

No more than two high speed starts per minute are permissible. The starting voltage must never exceed 600 volts rms.

#### Stator Cord:

A six wire shield-grounded stator cord should be connected from the stator terminal to the motor control. All listed voltage and amperage measurements should be taken at the housing end.

If the stator cord is not provided, the cord used must be UL listed or a UL recognized component for all products used in the USA. Outside the USA, the cord used must comply with all applicable regulatory and statutory requirements for electrical and safety. The cord must have the following characteristics: six conductor, 18AWG (0.9mm<sup>2</sup>) Cu, rated 600V, 90°C minimum, shielded cable with PVC jacket 0.032 inch (0.081mm) thick minimum. Lead terminations are provided and must be used with wire that matches the above description.

#### 定子功率:

阳极达到全速的时间是“启动器”的额定功率以及阳极重量和直径的函数。万睿视影像所有型号的定子都按常速和高速启动器进行了检定。102 mm (4.0 in.) 阳极系列管达到全速的时间在 1.3 到 2.0 秒之间。

高速阳极旋转后，转子的速度必须立即下降到 4000 转/分钟，或使用合适的电动制动装置在 10 秒内减速。

每分钟不允许有两次以上的高速启动。启动电压决不能高于600 伏 rms。

#### 定子电缆:

六导线接地屏蔽定子电缆应该从定子端连接到电机控制装置。在管套端，应该采用所列的所有电压和电流测量。如果未提供定子电缆，则所用的电缆必须是 UL 所列或经 UL 验证适用于美国所用全部产品的组件。

如果不在美国，则所用的电缆必须符合所有适用的电气和安全法规要求。此电缆必须拥有下列特性：六根导线，18 AWG (0.9mm<sup>2</sup>) 铜制，额定电压 600V，最低温度90°C，电缆上覆有最低厚度为 0.032 in. (0.081 mm) 的 PVC 护套。提供了导线端子，并且必须将其与符合上述说明的电线结合使用。

### Standard Wiring 标准接线图

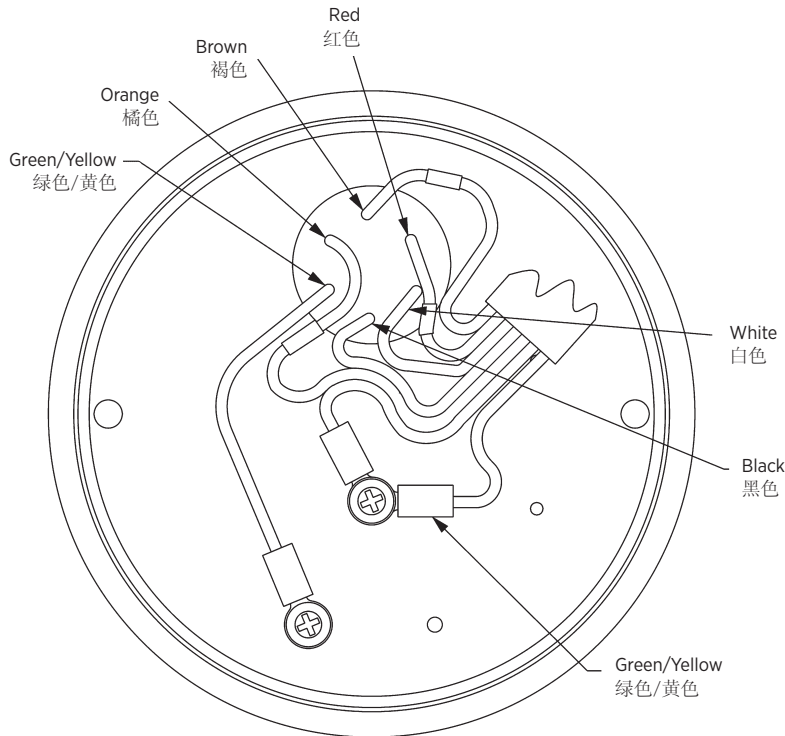

Wire Color 导线颜色	Description 描述
White 白色	Common 公共
Black 黑色	Phase 相
Red 红色	Phase Shift 相移
Orange 橘色	Thermal Switch 热控开关
Brown 褐色	Thermal Switch 热控开关
Green/Yellow 绿色/黄色	Housing Ground 管套接地线

### Optional Wiring 可选接线图

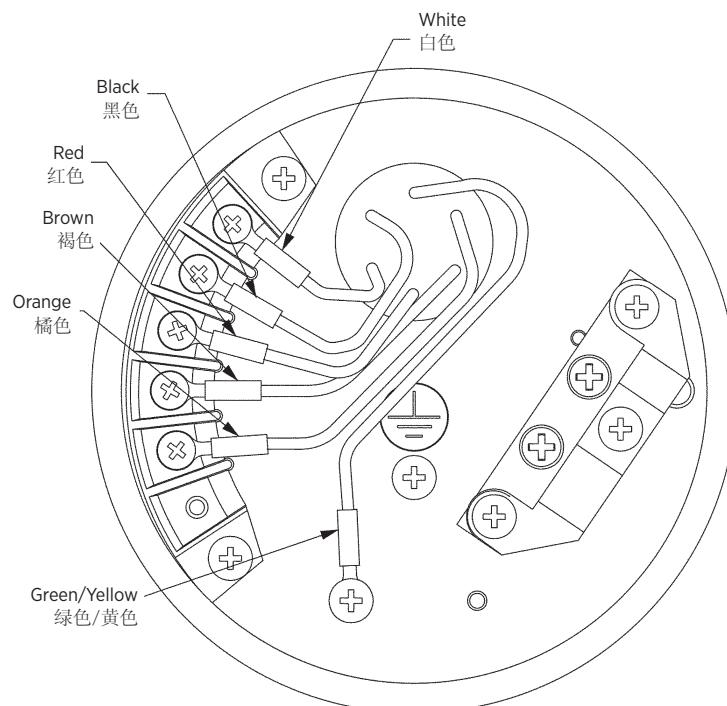

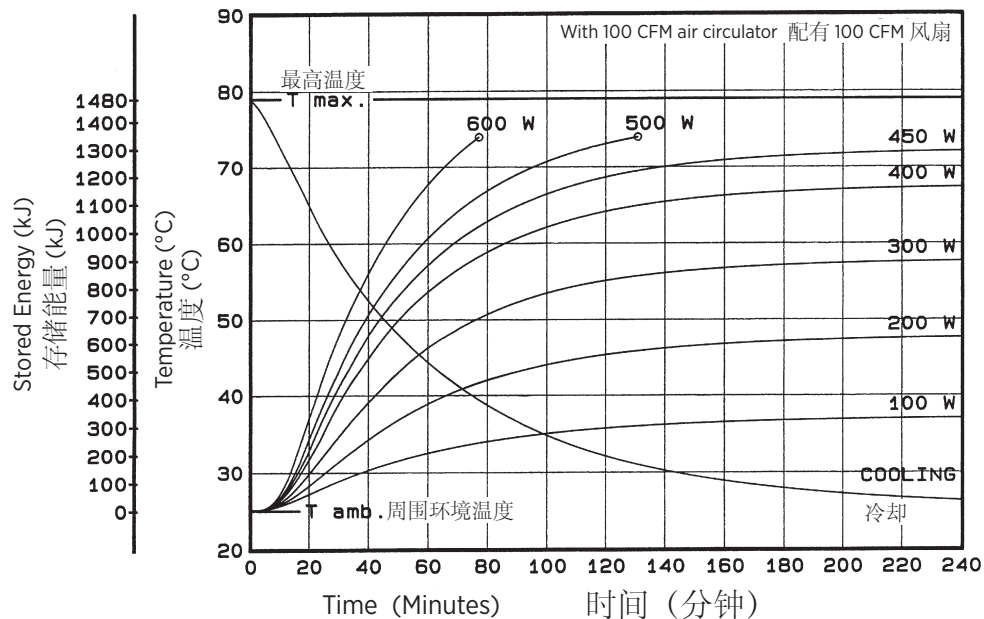
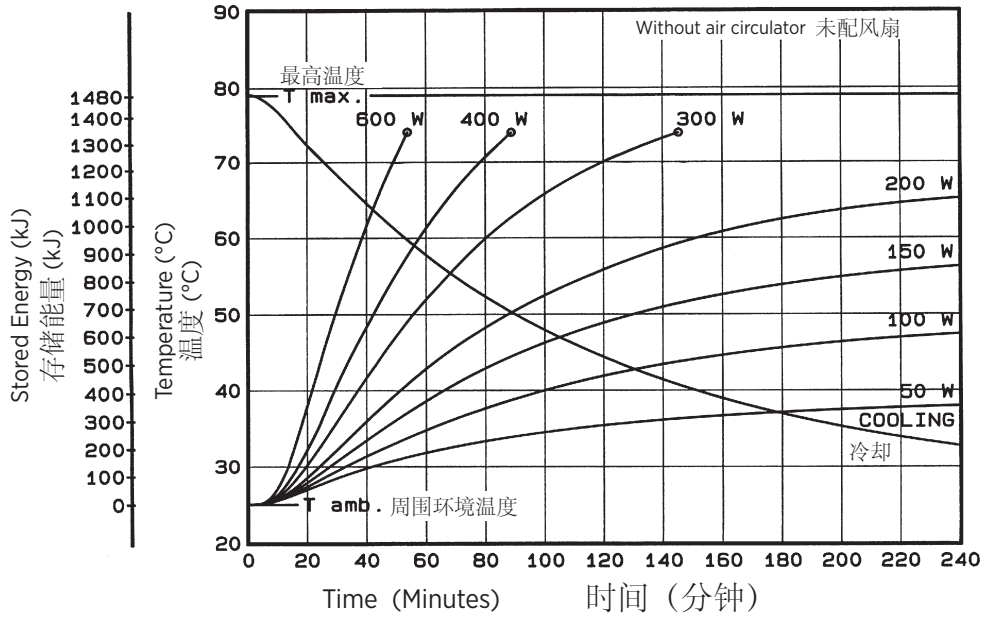

**Note:**

Heat inputs into housing include tube power, filament power, and stator power. Heating curves based on no restrictions of natural convection around tube housing assembly.

**注释:**

向管套的热量输入包括管功率、灯丝功率和定子功率。加热曲线以管套组件周围无自然对流的限制为根据。

Tube Coverage Chart  
Source to Receptor Distance (centimeters)  
射线管覆盖范围图  
射线源到接收器之间的距离 (厘米)

